



0086

BS EN ISO 9001



FM 00707



Worcester

*V-Flow Control Valves
For High Performance Applications*

Worcester's patented metal seat technology has opened a new chapter in the history of modulating control.

The V~Flow control valve combines the simplicity of a process ball valve with the revolutionary characterised seat concept.

Traditional control valves

- Typically single or double ported globe valves powered by spring diaphragm actuators with yoke type linkages
- Good flow characteristics and capability to handle high pressure drops

Have you experienced . . .

- Slow valve response to set point process changes?
- Excessive weight valve packages?
- Rising stem packing leakage and "sticking" in service?
- Limited flow capacity and turndown ratio?
- Poor valve shut-off performance?
- Expensive subcontract maintenance?
- Product failure and lost production downtime?

Problems with linear Globe control valves

- The rising stem design is prone to leakage and sticking in service
- Low cycle life compared to modern rotary products
- Large pneumatic actuators required
- Actuator diaphragm leakage / breakdown
- Limited flow capacity
- Clogging of flow path with solid / fibrous media
- High purchase price and cost of ownership
- Time consuming, expensive maintenance
- Poor performance on throttling applications
- Problems with hysteresis, friction and linkages



The Modern Control Valve Solution: Rotary

- More flow capacity for your money
- Excellent performance on throttling applications
- Capability with solid solutions, fibrous media and slurries
- High turndown / rangeability
- Bubble tight shut-off - eliminates need for isolation valves
- Compact and lightweight package
- Flexibility through innovative seat design
- Excellent pressure drop recovery performance
- Total cost-effective in-house maintenance possible
- Dynamic sealing on a rotary shaft offers excellent cycle life
- Virtually no hysteresis from direct drive design
- Excellent repeatability
- Unobstructed flow path gives high flow capacity
- Equal percentage characteristic as standard due to porting configuration



Direct Drive for Minimal Hysteresis

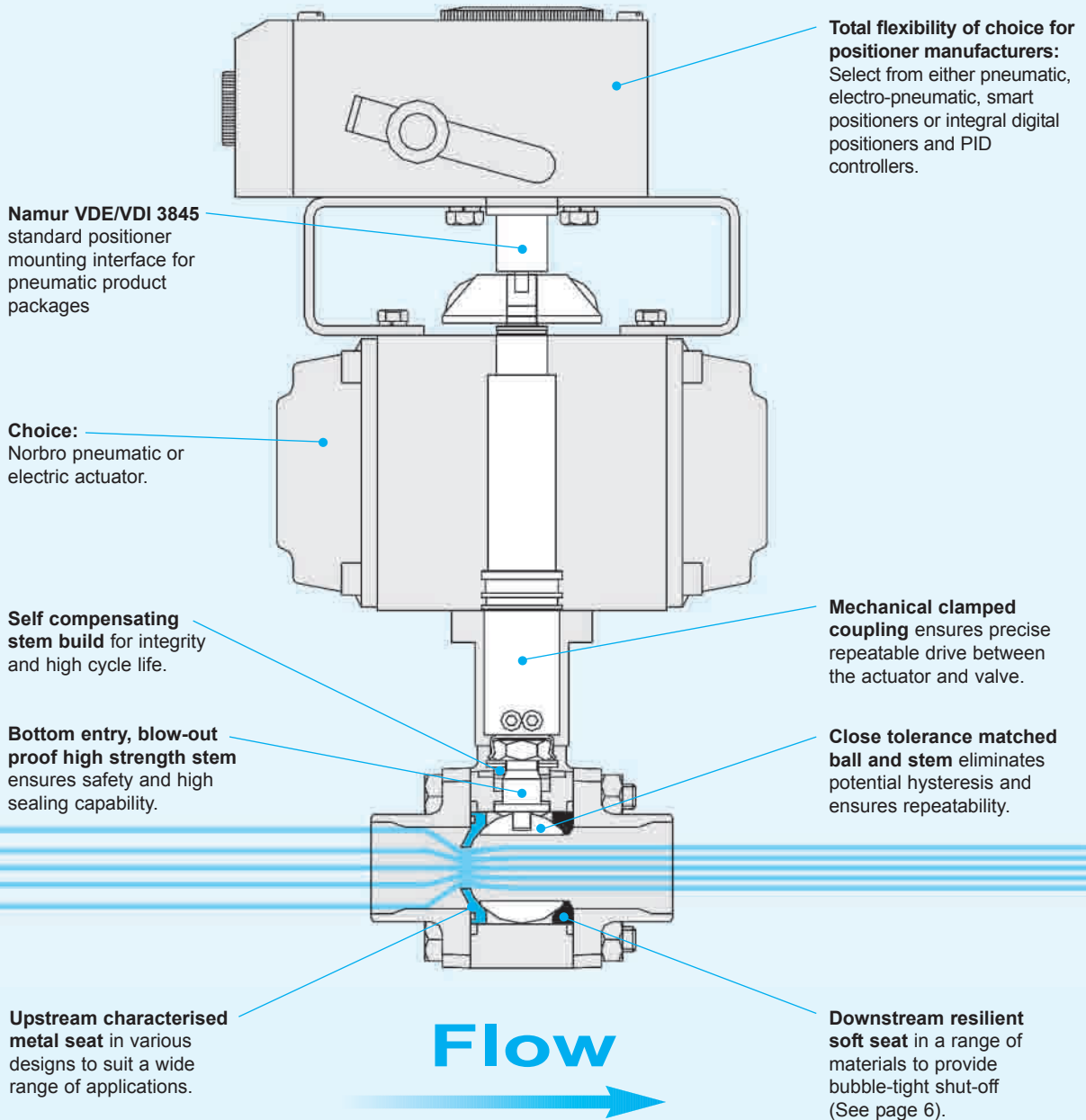

Typical V~Flow Configurations

3-PIECE VALVES

Worcester 3-piece V~Flow control valves are designed for the requirements of advanced processes: compact size, low cost reparability, long service life, fluid / material compatibility and tight shut-off.

With the characterised seat control valve, if the existing valve flow co-efficient (C_v) is incorrect, or process parameters change, this can be corrected by simply fitting an alternative seat with the appropriate aperture.

Features include:

- Size range 8 - 200mm* with a full selection of Worcester body end connections for versatile applications
- 3-Piece design allows “swing out” body feature eliminating unions and simplifying servicing and maintenance
- Normal availability in carbon steel, 316 stainless steel, aluminium and brass with a wide range of other materials available
- Compact design extended for special services including Cryogenics, Steam, Oxygen, etc.

* Full range of characterised seats available up to 80mm.



FLANGED VALVES

Worcester's flanged V~Flow valves, designed to BS5351, are robust control valves recommended for high flow and high pressure rating applications.



Features include:

- Class 150 and 300 rated in sizes 15 - 200mm*
- One piece body and flange construction machined to A.N.S.I /DIN Standards
- Carbon steel or 316 stainless steel body (standard)
- Simple mounting to range of Norbro Pneumatic or Electric valve actuators
- Available in Worcester's full range of flanged and wafer valve designs
- Valves can be supplied in the Enviro-Safe high integrity / high cycling stem design

* Full range of characterised seats available up to 100mm.

Downstream Seat Selection



VIRGIN PTFE (T)

Virgin PTFE is the most common sealing material and is suitable for almost all media as it has excellent chemical resistance.

Maximum pressure 69 bar.
Maximum temperature 230°C.



UHMWPE (U)

Ultra High Molecular Weight Polyethylene offers good performance characteristics in applications where PTFE is not suitable (for example on tobacco duty).

Maximum pressure 100 bar.
Maximum temperature 90°C.



RE-INFORCED PTFE (R)

Glass re-inforced PTFE seats are stronger than virgin and have higher pressure/temperature ratings.

Chemical resistance as per virgin PTFE.
Maximum pressure 102 bar.
Maximum temperature 230°C.



ACETAL (Y)

Machined from acetal homopolymer, these seats are capable of handling extremely high pressures. Please note this material should not be used on oxygen service.

Maximum pressure 207 bar.
Maximum temperature 80°C.



VXI (H)

VXI is a glass re-inforced PTFE material offering a greater pressure/temperature capability than the R seat.

Maximum pressure 102 bar.
Maximum temperature 260°C.



PEEK (X)

PEEK is Poly Ether Ether Ketone, a material which demonstrates outstanding pressure capabilities at elevated temperatures. PEEK has excellent chemical and abrasion resistance.

Maximum pressure 207 bar.
Maximum temperature 280°C.



FLUOROFILL (P)

Carbon, glass and graphite filled PTFE material, an excellent seat material for steam and thermal services as well as having good abrasion resistance. Due to its high cycling capabilities, it is the recommended soft seat for modulating control applications.

Maximum pressure 102 bar.
Maximum temperature 260°C.



METAL – ALPHA (A)

A 316L sintered metal seat impregnated with PTFE, this material combines the strength and abrasion resistance of metal with the lubrication properties of PTFE. A graphite-impregnated metal seat is also available.

UPSTREAM SEAT SELECTION

(SOME TYPICAL EXAMPLES)

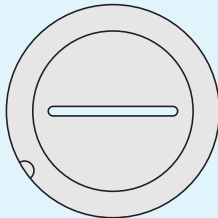

Slotted Seat
(linear characteristic)

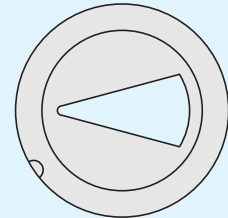

30° Seat
(equal percentage)

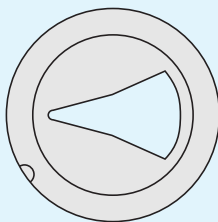
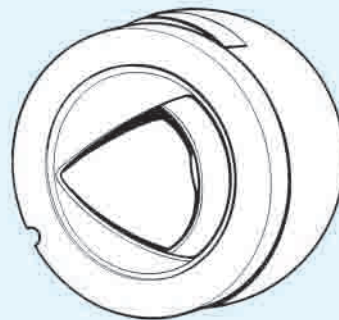

Custom Seats
(special applications)

The relationship between ball position and characterised seat allows for precision throttling control. The V~Flow control valves are sized to ideally control between 20 - 80% opening of the valve.

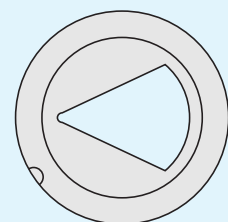

60° Seat
(equal percentage)

Flow Characteristic Options

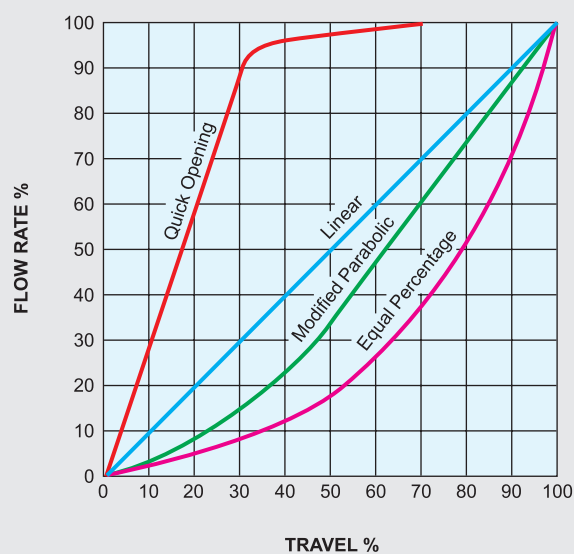

High Performance Pneumatic Control

The high performance pneumatic control valve package is based on the Series 40R actuator. Developed from the original patented Norbro design, the Series 40R is an efficient, compact, powerful double rack and pinion actuator. A comprehensive range of twelve product sizes of both double acting and spring return pneumatic actuators are available, allowing the optimum product selection to suit the control valve torque requirement.

The precision engineering of the Series 40R actuator permits high torque performance with minimal backlash and potential hysteresis. Standardisation on the NAMUR VDE/VDI 3845 interface offers total flexibility of positioner product selection.

PROVEN, RELIABLE PERFORMANCE

- Unique support rod operation for long life and low cost of ownership
- Compact, space saving and robust design
- High torque output for product size
- Large size range for efficient torque selection
- Over 30 years of field proven reliable performance
- Safe and easy to maintain

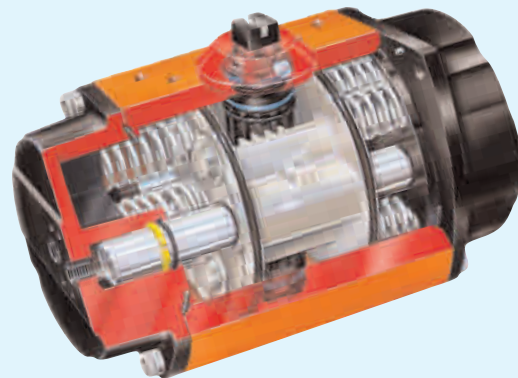

PRODUCT OPTIONS

- Pneumatic positioner (3-15 psi input)
- Electro-pneumatic positioner (4-20mA input)
- Digital positioner
- Intelligent positioner (diagnostics, self calibration etc.)
- Fieldbus protocols (e.g. HART, Fieldbus Foundation etc.)
- Accessories e.g. limit switches, feedback modules, gauges etc.
- Available for all safe and hazardous area applications

The Worcester V~Flow control valve, pneumatic actuator and choice of positioner therefore represents the ideal automated pneumatic control valve solution ...

Technology Driven Electrical Control

The Series 75 electric actuator provides an obvious alternative to pneumatic product options. The compact and powerful electric actuator is available in seven sizes, allowing the optimum product selection to suit the control valve torque requirement.

The electric actuator adds a new dimension of operational dependability and flexibility for modern process control applications, with simple interfacing to both analogue and digital control devices and systems. For modulating duty applications, the Series 75 electric actuator is fitted with an integral accessory from the Dataflo Smart product family.

The **Dataflo P** is a fully integral digital positioner, controlled by either an analogue control signal, from a PLC, or remotely from a computer. The Dataflo P optimises the performance of your control valve, and turns your final control element into an efficient digital communications platform.

The **Dataflo C** is a fully functional PID (Proportional Integral Derivative) controller. This single loop controller integrates set point PID control into the rotary control valve package. The Dataflo C operates from a single process input from suitable instrumentation, thereby eliminating the need and cost of a valve positioner, a remote set point controller and associated installation equipment.

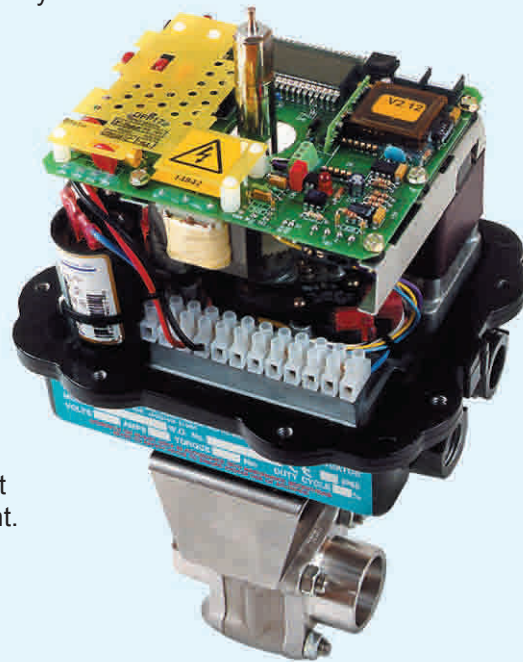

DataFlo - smart product solutions...



- Digital communication with the control valve
- Digital positioner option
- Integral PID controller operating from one selected process input
- Compact integral product solutions
- Extensive range of accessories
- Fieldbus protocols being developed
- Direct interfacing to modern process control systems

For more information please refer to the Flowserve product literature.

Applications

STEAM CONTROL

Controlling steam pressure is not easy. Typical problems associated with globe control valves in steam service have been stem leakage, sticking, poor shut-off and high maintenance. Linear stem valves require frequent packing adjustment and tightened packing sometimes means overshoot, oscillation and deviation from the setpoint. Further, Class IV shut-off is usually excessive leakage for many applications requiring tight shut-off.

Worcester V~Flow control valves solve these problems with tight shut-off exceeding Class VI, self-compensating rotary stem seals and tailored seat characteristics provide slow valve opening and quick process ramp up whilst maintaining precise low flow control. Thousands of V~Flow control valves are successfully operating in steam systems where globe valves were originally used.



TOXIC FLUIDS / MEDIA

Traditional rising stem globe valves cannot stand up to the demanding specifications recently implemented by the EPA, OSHA and other regulating agencies. The very nature of the design, even with double packing and/or bellows seals have relatively short cycle lives compared to dynamic rotary seals. The EnviroSAFE V~Flow control valve has been certified by third party testing allowing less than 20 ppm. Self-adjusting dual stem sealing with multiple Belleville washers make this valve ideal for throttling toxic chemicals.

Applications

PH CONTROL

PH process control loops are associated with low flow rates that require control valves offering repeatable fine control. These applications create major problems for traditional rising stem control valves, where solids exist in the flow media that are typically larger than the control valve opening. This can cause blockage of the control valve, resulting in product failure and expensive maintenance downtime.

V~Flow is the ideal control valve for pH control when using a low flow opening and solid removal hole. The special design of the pH control seats provide ideal throttling characteristics and turndown while allowing solids to move out of the larger opening. Also erosion problems are minimised and valve body is protected due to the location of the *vena contracta* being located outside the valve body.

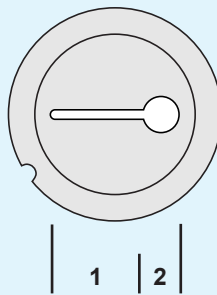
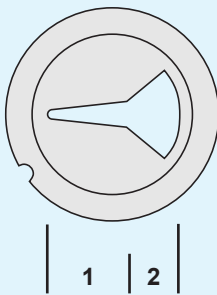

1 Control Area
2 Solid Flush Area

CRYOGENICS

Compactness, balanced weight, precision control, tight shut-off and long service life are features considered unique and unmatched by conventional control valve designs. The cryogenic characterised seat valve is designed to handle large temperature variations with its special seats and self compensating rotary stem seal design.

These features make the V~Flow an ideal control valve for low temperature and cryogenic applications such as freezing systems, lyophilization systems, high purity gas systems, terminal loading stations, over-the-road CO₂, LNG food carriers and air separation systems. The characterised valve provides tailored flow characteristics for each process, in the body and trim materials you require. V~Flow control valves can be easily and economically controlled by either the pneumatic or electric range of actuators.



Flow Coefficient - C_v

Round Port Control Valves

Percent of Rated Travel (degrees Rotation)												
Valve Size	Line Size	0 (0)	10 (9)	20 (18)	30 (27)	40 (36)	50 (45)	60 (54)	70 (63)	80 (72)	90 (81)	100 (90)
15	15	0	0.15	0.29	0.46	0.70	1.09	1.76	2.60	4.30	6.40	8.00
	20	0	0.13	0.26	0.39	0.62	0.97	1.57	2.31	3.83	5.69	7.12
	25	0	0.13	0.24	0.38	0.58	0.90	1.46	2.16	3.57	5.31	6.64
20	20	0	0.21	0.43	0.70	1.05	1.62	2.64	4.00	6.40	9.60	12.00
	25	0	0.19	0.39	0.64	0.96	1.47	2.40	3.64	5.82	8.74	10.92
	40	0	0.17	0.34	0.56	0.84	1.30	2.11	3.20	5.12	7.68	9.60
25"	25	0	0.58	1.15	1.90	2.80	4.30	7.00	10.5	17.0	26.0	32.0
	40	0	0.45	0.90	1.48	2.18	3.35	5.46	8.19	13.3	20.3	24.9
	50	0	0.42	0.83	1.37	2.02	3.10	5.04	7.56	12.24	18.7	23.1
32	32	0	0.83	1.65	2.67	4.05	6.50	10.0	15.2	24.6	36.0	46.0
	40	0	0.77	1.53	2.48	3.77	6.05	9.30	14.14	22.9	33.5	42.8
	50	0	0.68	1.35	2.19	3.32	5.33	8.20	12.46	20.2	29.5	37.7
40	40	0	1.48	2.95	4.75	7.20	11.0	18.0	27.0	44.0	65.5	82.0
	50	0	1.24	2.48	3.99	6.05	9.2	15.1	22.7	36.9	55.0	68.9
	80	0	.99	2.00	3.18	4.82	7.4	12.06	18.1	29.5	43.9	54.9
50	50	0	2.06	4.33	6.95	10.5	16.2	26.4	39.6	64.0	96.0	120.0
	80	0	1.77	3.55	5.70	8.61	13.3	21.6	32.5	52.5	78.7	98.4
	100	0	1.60	3.20	5.14	7.77	11.99	19.5	29.3	47.4	71.1	88.8
80	80	0	6.4	12.6	20.2	31.1	47.4	77.8	115.0	187.0	280.0	350.0
	100	0	4.6	9.1	14.5	22.4	34.1	56.0	82.9	134.0	201.0	252.0
	150	0	3.5	6.9	11.1	17.1	26.1	42.8	63.3	103.0	154.0	192.0
100	100	0	13.1	26.0	42.1	63.1	97.2	159.0	238.0	385.0	575.0	720.0
	150	0	7.5	16.9	27.4	41.0	63.2	103.0	154.0	251.0	374.0	467.0
	200	0	7.2	14.3	23.1	34.7	53.5	87.4	131.0	212.0	316.0	396.0
150	150	0	18.4	36.7	59.0	90.0	138.0	224.0	338.0	545.0	815.0	1020.0
	200	0	16.2	32.3	51.9	79.2	121.4	197.1	297.4	479.6	717.2	897.6
	250	0	14.4	28.6	46.0	70.2	107.6	174.7	263.6	425.1	635.7	795.6
200	200	0	34.0	68.0	109.0	165.0	254.0	415.0	620.0	1010.0	1500.0	1880.0
	250	0	31.9	63.9	102.5	155.1	238.8	390.1	582.8	949.4	1410.0	176.2
	300	0	88.6	57.1	91.6	138.6	213.4	348.6	520.8	848.4	1260.0	1580.0

C_v is defined as the flow of liquid in U.S. gallons per minute through a valve with a pressure drop of one psi across the valve.

F_L	0	0.92	0.91	0.91	0.90	0.86	0.80	0.72	0.61	0.61	0.50
X_1	0	0.78	0.74	0.71	0.67	0.62	0.56	0.49	0.38	0.26	0.15

F_L = Liquid Pressure Recovery Factor

X_1 = Pressure Drop Ratio Factor (Gas)

Flow Coefficient - C_v

Characterised Seat Control Valves

Percent of Rated Travel (degrees Rotation)												
Valve Size	Line Size	0 (0)	10 (9)	20 (18)	30 (27)	40 (36)	50 (45)	60 (54)	70 (63)	80 (72)	90 (81)	100 (90)
1/2" 1/32" widedslot	15	0	0	0.033	0.074	0.115	0.156	0.197	0.238	0.279	0.320	0.361
	20	0	0	0.029	0.066	0.102	0.139	0.175	0.212	0.248	0.285	0.321
	25	0	0	0.027	0.061	0.095	0.129	0.163	0.177	0.208	0.265	0.300
1/2" 1/16" widedslot	15	0	0	0.07	0.20	0.33	0.46	0.60	0.73	0.86	0.99	1.10
	20	0	0	0.06	0.18	0.29	0.41	0.53	0.65	0.77	0.88	0.98
	25	0	0	0.06	0.17	0.27	0.38	0.50	0.61	0.71	0.82	0.91
1/2" 30°V	15	0	0.01	0.10	0.20	0.34	0.55	0.83	1.11	1.59	2.08	2.50
	20	0	0.01	0.09	0.18	0.30	0.49	0.74	0.99	1.41	1.85	2.22
	25	0	0.01	0.08	0.17	0.28	0.46	0.69	0.92	1.32	1.73	2.07
1/2" 60°V	15	0	0.01	0.12	0.33	0.49	0.84	1.35	1.95	3.10	4.37	5.92
	20	0	0.01	0.10	0.29	0.44	0.75	1.20	1.74	2.76	3.90	5.27
	25	0	0.01	0.10	0.27	0.41	0.70	1.12	1.62	2.57	3.63	4.91
3/4" 1/32" widedslot	20	0	0	0.038	0.084	0.131	0.178	0.225	0.271	0.318	0.365	0.412
	25	0	0	0.012	0.078	0.122	0.165	0.209	0.227	0.267	0.339	0.385
	40	0	0	0.004	0.072	0.114	0.153	0.195	0.189	0.224	0.315	0.360
3/4" 1/16" widedslot	20	0	0	0.080	0.228	0.376	0.524	0.684	0.832	0.980	1.128	1.254
	25	0	0	0.066	0.203	0.324	0.461	0.594	0.730	0.866	0.987	1.100
	40	0	0	0.055	0.180	0.280	0.405	0.515	0.640	0.764	0.864	0.965

Flow Coefficient - C_v

Characterised Seat Control Valves

		Percent of Rated Travel (degrees Rotation)										
Valve Size	Line Size	0 (0)	10 (9)	20 (18)	30 (27)	40 (36)	50 (45)	60 (54)	70 (63)	80 (72)	90 (81)	100 (90)
3/4" 1/8" widedslot	20	0	0	0.316	0.391	0.646	0.901	1.180	1.435	1.689	1.944	2.158
	25	0	0	0.116	0.329	0.551	0.765	1.002	1.216	1.437	1.651	1.838
	40	0	0	0.099	0.277	0.470	0.649	0.852	1.031	1.223	1.402	1.565
1/4" 30°V	20	0	0.012	0.105	0.239	0.408	0.666	1.006	1.393	1.936	2.554	3.043
	25	0	0.012	0.094	0.213	0.354	0.585	0.883	1.225	1.688	2.238	2.660
	40	0	0.012	0.083	0.189	0.307	0.513	0.776	1.077	1.472	1.960	2.325
3/4" 60°V	20	0	0.012	0.134	0.360	0.550	0.970	1.547	2.253	3.562	5.005	6.739
	25	0	0.012	0.134	0.335	0.512	0.905	1.444	2.098	3.316	4.660	6.281
	40	0	0.012	0.0134	0.312	0.476	0.844	1.347	1.953	3.088	4.338	5.854
1" 1/32" widedslot	25	0	0	0.062	0.140	0.217	0.294	0.372	0.450	0.527	0.604	0.682
	40	0	0	0.055	0.125	0.193	0.263	0.331	0.400	0.468	0.538	0.606
	50	0	0	0.051	0.115	0.179	0.243	0.308	0.334	0.393	0.500	0.567
1" 1/16" widedslot	25	0	0	0.0133	0.380	0.627	0.873	1.139	1.386	1.633	1.880	2.090
	40	0	0	0.114	0.342	0.551	0.779	1.006	1.234	1.462	1.671	1.861
	50	0	0	0.114	0.323	0.513	0.722	0.949	1.158	1.348	1.557	1.728
1" 1/8" widedslot	25	0	0	0.23	0.66	1.09	1.52	1.99	2.42	2.85	3.28	3.64
	40	0	0	0.20	0.57	0.95	1.32	1.73	2.10	2.48	2.85	3.17
	50	0	0	0.19	0.54	0.89	1.25	1.63	1.98	2.34	2.69	2.98
1" 30°V	25	0	0.03	0.21	0.56	0.96	1.58	2.39	3.43	4.62	6.15	7.26
	40	0	0.02	0.16	0.44	0.75	1.23	1.86	2.68	3.60	4.80	5.66
	50	0	0	0.15	0.40	0.69	1.14	1.72	2.47	3.33	4.43	5.23
1" 60°V	25	0	0.03	0.30	0.78	1.24	2.27	3.59	5.28	8.29	11.6	15.5
	40	0	0.02	0.23	0.61	0.97	1.77	2.80	4.12	6.47	9.05	12.1
	50	0	0.02	0.22	0.56	0.89	1.63	2.58	3.80	5.97	8.35	11.2
1 1/2" 1/32" widedslot	40	0	0	0.097	0.218	0.338	0.458	0.580	0.702	0.822	0.642	1.064
	50	0	0	0.090	0.201	0.314	0.424	0.540	0.586	0.690	0.875	0.995
	65	0	0	0.083	0.185	0.291	0.391	0.503	0.489	0.580	0.813	0.932
1 1/2" 1/16" widedslot	40	0	0	0.208	0.593	0.979	1.362	1.778	2.163	2.549	2.934	3.262
	50	0	0	0.208	0.560	0.911	1.263	1.676	2.029	2.350	2.734	3.030
	65	0	0	0.208	0.530	0.848	1.171	1.581	1.903	2.166	2.549	2.815
1 1/2" 1/8" widedslot	40	0	0	0.364	1.045	1.726	2.407	3.152	3.833	4.514	5.195	5.765
	50	0	0	0.310	0.880	1.172	2.043	2.678	3.249	3.840	4.411	4.910
	65	0	0	0.263	0.741	1.255	1.733	2.275	2.753	3.267	3.745	4.182
1 1/2" 30°V	40	0	0.049	0.406	1.158	2.124	3.507	5.219	7.564	10.279	13.714	16.278
	50	0	0.049	0.380	1.053	1.954	3.135	4.828	6.80	9.508	12.658	15.040
	65	0	0.049	0.356	0.957	1.798	2.803	4.466	6.113	8.795	11.683	13.897
1 1/2" 60°V	40	0	0.05	0.572	1.744	2.992	5.587	9.073	13.157	19.798	28.415	37.511
	50	0	0.05	0.525	1.601	2.756	5.145	8.356	12.131	18.274	26.227	34.735
	65	0	0.05	0.482	1.470	2.538	4.739	7.696	11.185	16.867	24.208	32.164
2" 30°V	50	0	0.05	0.55	1.72	3.41	5.65	8.26	12.1	16.6	22.2	26.5
	80	0	0.04	0.45	1.41	2.80	4.63	6.77	9.92	13.6	18.2	21.7
	100	0	0.04	0.41	1.27	2.52	4.18	6.11	8.95	12.3	16.4	19.6
2" 60°V	50	0	0.05	0.70	2.64	4.90	9.32	15.5	22.2	32.1	47.2	61.6
	80	0	0.04	0.57	2.16	4.02	7.64	12.7	18.2	26.3	38.7	50.5
	100	0	0.04	0.52	1.95	3.63	6.90	11.5	16.4	23.8	35.9	45.6
3" 30°V	80	0	0.10	0.75	2.68	6.00	10.2	16.9	24.5	33.9	44.8	54.2
	100	0	0.07	0.54	1.93	4.32	7.34	12.2	17.6	24.4	32.3	39.0
	150	0	0.06	0.41	1.47	3.30	5.61	9.30	13.5	18.6	24.6	29.8
3" 60°V	80	0	0.10	0.95	4.25	10.1	18.6	29.4	46.3	67.2	94.4	124.6
	100	0	0.07	0.68	3.06	7.27	13.4	21.2	33.3	48.4	68.0	98.7
	150	0	0.06	0.52	2.34	5.56	10.2	16.2	25.5	37.0	51.9	68.5
4" 30°V	100	0	0.10	0.80	3.59	8.50	16.1	26.8	40.2	56.5	72.5	89.8
	150	0	0.07	0.52	2.33	5.53	10.5	17.4	26.1	36.8	47.1	58.4
	200	0	0.06	0.44	1.97	4.68	8.86	14.7	22.1	31.1	39.9	49.4
4" 60°V	100	0	0.10	0.90	5.69	15.4	28.8	48.6	73.4	107.0	150.7	200.0
	150	0	0.07	0.59	3.70	10.0	18.7	31.6	47.7	69.6	98.0	130.0
	200	0	0.06	0.50	3.13	8.47	15.8	26.7	40.4	58.9	82.9	110.0

C_v is defined as the flow of liquid in U.S gallons per minute through a valve with a pressure drop of one psi across the valve.

F_L	0	0.96	0.95	0.94	0.93	0.92	0.90	0.88	0.86	0.82	0.75
X_t	0	0.72	0.65	0.60	0.54	0.48	0.42	0.36	0.28	0.16	0.12

F_L = Liquid Pressure Recovery Factor X_t = Pressure Drop Ratio Factor (Gas)

Pneumatic V~Flow Valves

3-PIECE VALVES

Series 44/459 with Norbro 40R series actuator and PMV P5 positioner

Valve Size	Actuator Size D/A or S/A	A	B	C	D	E
15mm	10	266	110	84	50	50
20mm	15	294	118	104	50	50
25mm	15	296	118	104	50	50
40mm	20	321	138	124	58	58
50mm	20	326	138	124	58	58
	25	356	156	142	68	68
80mm	25	422	156	142	68	68
	30	463	184	169	78	78
100mm	33	510	220	206	103	103
	35	528	220	206	103	103
	40	531	232	218	107	107
		646	275	261	123	123

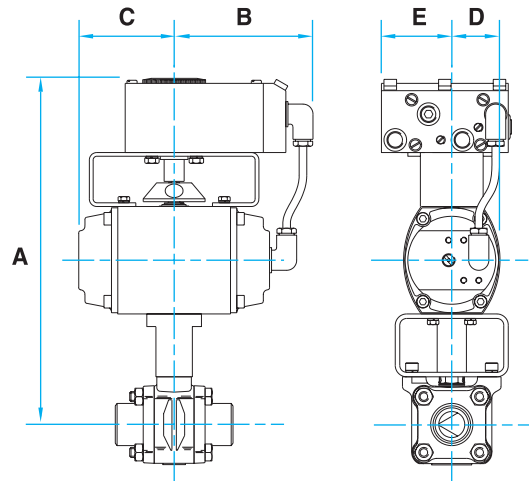

For valve dimensions see individual product literature.

FLANGED VALVES

Series 51/52/53/54 with Norbro 40R series actuator and PMV P5 positioner

Valve Size	Actuator Size D/A or S/A	A	B	C	D	E
15mm	10	260	110	84	50	50
20mm	15	287	118	104	50	50
25mm	15	289	118	104	50	50
40mm	20	331	138	124	58	58
50mm	20	336	138	124	58	58
	25	367	156	142	68	68
80mm	30	388	184	169	78	78
	25	439	156	142	68	68
100mm	30	460	184	169	78	78
	33	506	220	206	103	103
100mm	33	522	220	206	103	103
	35	525	232	217	107	107
	40	624	275	261	123	123

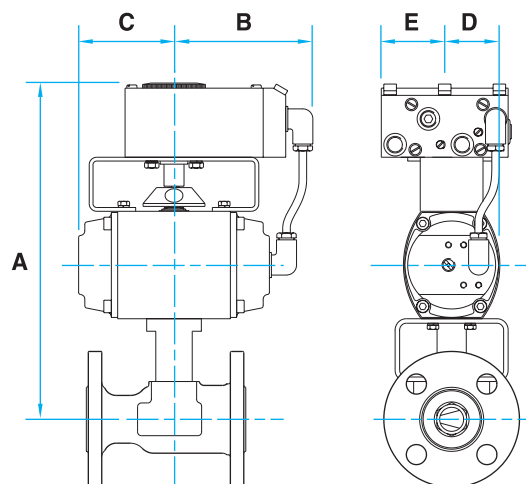

For valve dimensions see individual product literature.

Electric V~Flow Valves

FLANGED VALVES

Series 44/459 with Norbro 75 series actuator

Valve Size	Actuator Size	A	B	C	D	E
15mm	10 - 12	292	98	98	78	92
20mm	10 - 12	294	98	98	78	92
25mm	15 - 22	323	98	98	78	92
40mm	15 - 22	317	98	98	78	92
50mm	15 - 22	322	98	98	78	92
80mm	25 - 30	567	98	98	78	92
100mm	25 - 30	585	98	98	78	92

For valve dimensions see individual product literature.

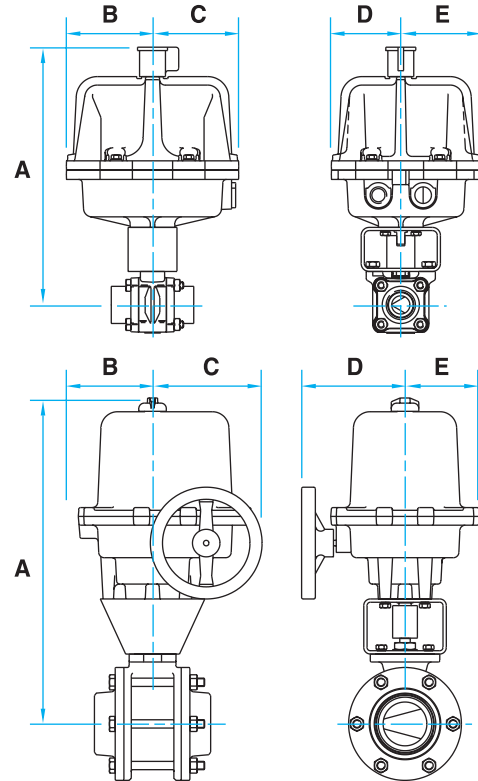

FLANGED VALVES

Series 51/52/53/54 with Norbro 75 series actuator

Valve Size	Actuator Size	A	B	C	D	E
15mm	10 - 12	286	98	98	78	92
20mm	10 - 12	288	98	98	78	92
25mm	15 - 22	316	98	98	78	92
40mm	15 - 22	327	98	98	78	92
50mm	15 - 22	332	98	98	78	92
80mm	25 - 30	563	98	98	78	92
100mm	25 - 30	579	98	98	78	92

For valve dimensions see individual product literature.

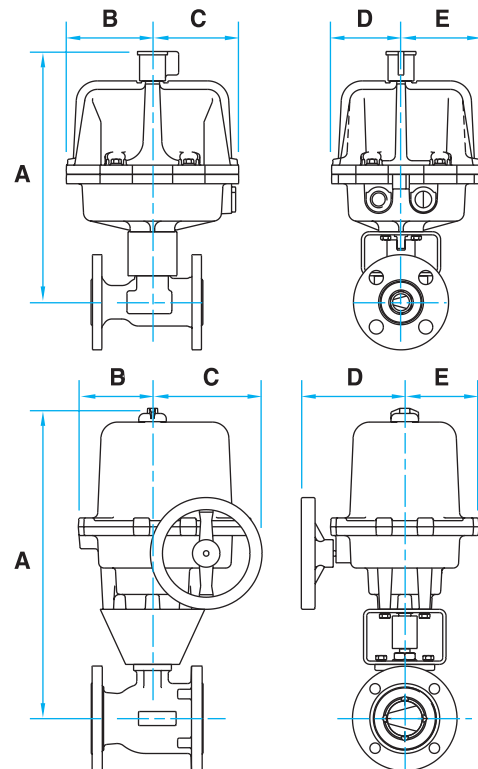

When specifying, please give as much of the following information as possible for each application

Control valve sizing and actuator specification sheet

Service conditions

- 1 Flow rate
- 2 Pressure
- 3 Temperature
- 4 Viscosity
- 5 Media type
- 6 SG/density/molecular weight
- 7 Vapour pressure
- 8 Critical pressure
- 9 Inlet pipe size / schedule / thread type / butt or socket
- 10 Outlet pipe size / schedule / thread type / butt or socket

Unit	Minimum	Normal	Maximum

Control valve

- 11 Valve style / 3 piece / flanged / Class rating
- 12 Body & trim materials

Pneumatic actuator & positioner

- 13 Air pressure available
- 14 Spring return / double acting
- 15 Air fail close / air fail open
- 16 Positioner manufacturer (if preference)
- 17 Control signal (3-15 psi/4-20mA/HART)
- 18 Enclosure approvals
- 19 Standard / reverse acting
- 20 Pneumatic thread type (BSPP/NPT)
- 21 Electrical thread type (M20 x 1.5p/½NPT/Pg13.5)

Electric actuator & positioner

- 22 Voltage supply
- 23 Enclosure approvals
- 24 Control signal (4-20mA / 0-10V / other)
- 24 Output signal (4-20mA / other)

Electric actuator & PID Controller

- 25 Voltage supply
- 26 Enclosure approvals
- 27 Instrumentation type
- 28 Instrumentation output signal
- 29 Setpoint input signal (1000 Ohm / 4-20mA)

Additional information:



Flowserve Flow Control (UK) Ltd
 Burrell Road, Haywards Heath, West Sussex RH16 1TL
 T: +44 (0)1444 314400 F: +44 (0)1444 314401
 E-mail: wwukinfo@flowserve.com
 Website: www.worcestercontrols.co.uk



Flow Control Division

TM indicates a trade mark of Worcester Controls Information given in this leaflet is made in good faith and based upon specific testing but does not, however, constitute a guarantee